

Fact Sheet

CWEmaxx 600

BIZERBA

Our versatile checkweigher CWEmaxx is suitable for a high throughput. The all-rounder among the checkweighers can be used for numerous applications and allows weighing of most varied products due to its IP rating.



More information
High performance
with a wide range of
solutions and options.

Specifications	Facts	Details
Weighing data	Weighing range: 600 g Scale division d: 0.2 g Verification scale interval e: 0.2 g Minimum load: 15 g	
Performance data	Max. throughput: 600 ppm Max. belt speed: 170 m/min Min. belt speed: 5 m/min	Depending on length of weighing conveyor Depending on length of weighing conveyor
Device version / material	Stainless steel	1.4301
Operating panel	12" color touchscreen	
Interfaces	USB, EDP 1, 8 inputs, 8 outputs, Ethernet	EDP 1 (RS232 or RS422 or TTY)
IP rating	IP65	Conveying unit Control cabinet Display
Transport	Left to right right to left 750-1,150 mm +/-30 mm	Conveying direction Transport height
Conveyor belt	Belt width: Belt lengths: Weighing conveyor length: Infeed conveyor length: Rejection conveyor length: Belt color: Roll diameter: Belt unit and quick-change belt system	100 mm Length specifications always as axle distance: 200, 250, 325 mm 400, 600 mm 600, 750 mm white 22 mm Rollers made of aluminum, surface hard coated
Ambient conditions	+10 °C to +40 °C 20 - 90%, non-condensing	Operating temperature Humidity
Energy supply	100 - 240 V, 50 - 60 Hz 500 - 750 VA 6 bar	Power supply Power consumption Compressed air supply
Software licenses	STATISTICS WEIGHT_CLASSES	To create statistics For classification of more than 3 products
Software variants	Code page software Unicode software	Data transfer (texts & strings) Data transfer (texts & strings) in UTF-8 coding
further characteristics	Article memory Weight classes Remote maintenance Web interface	100,000 80

	Sending of status e-mails	
Guide rails	available for all belt lengths	
Belt transition plates	available for all belt widths	closes the gaps between the belt bodies
Draft shield	from the top	reduces interfering influences resulting from drafts
	from the bottom	
Options	Facts	Details
Metrologically approved as per OIML R 87	Prepack regulations (FPV) control, verifiable only for weighing belt lengths from 200 mm to 325 mm	The checkweighers are metrologically approved as per accuracy class XIII (1) and therefore suitable for prepack regulations control.
Indexing belt length	400, 600 mm	Shaft distance
Rejection systems	Air-jet nozzle Double air-jet nozzle	Further rejection systems upon request
Compressed air tank for rejection system air jet nozzle	5 liter tank	Mandatory for air-jet nozzle
Reject bin	Stainless steel Dimensions (L x D x H) Opening (W x H) Dimensions (L x D x H) Opening (W x H) Container fill level check Ejection monitoring Lock for reject bin	325 x 300 x 750 mm 300 x 212 mm 425 x 380 x 750 mm 400 x 212 mm Light sensor 1 light sensor or 4 light sensors available as latch or lock
Protocol printer	Mounted to control cabinet	Incl. license LINE_PRINTER and serial interface
Signal lamp	2-color 3-color	Red = fault, green = device okay Red = fault, yellow = stop, green = belts running
Emergency stop function	EMERG STOP with belt switch-off EMERG STOP with pneumatic system and belt switch-off	Mounted to main column, turns off conveyor drives additionally switches off the pneumatic system
Emergency operation function	The conveyor belts of the checkweighers can be started manually even if the operating and control unit failed.	The belts run in order to ensure the production flow (without weighing function). Operation via extra module in the control cabinet with adjustable belt speeds.
Tendency control kit	Incl. license Tendency Control and relay	
Line integration kit	3 outputs via relay and 1 input	
Flow control	Light sensor	
Compressed air monitoring	stops the system when air pressure drops	
Software licenses	BRIDGE+MC_BUFFER VERIFIABLE_X1 ETHERNET ONLINE SOFTCONTROL TENDENCY CONTROL LINE_PRINTER	For buffering data in the event of LAN / pc failure as per prepack regulations, incl. conformity assessment Ethernet connection via TCP/IP Communication via Gx-Net via ETHERNET For operation from a second work station To regulate filling systems (without relay) Required for external printer

Info graphics



Symbols

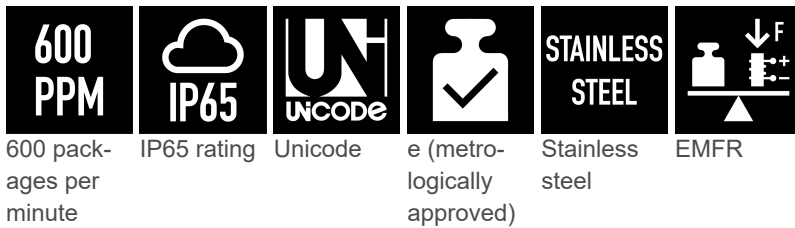

Dimensional drawings

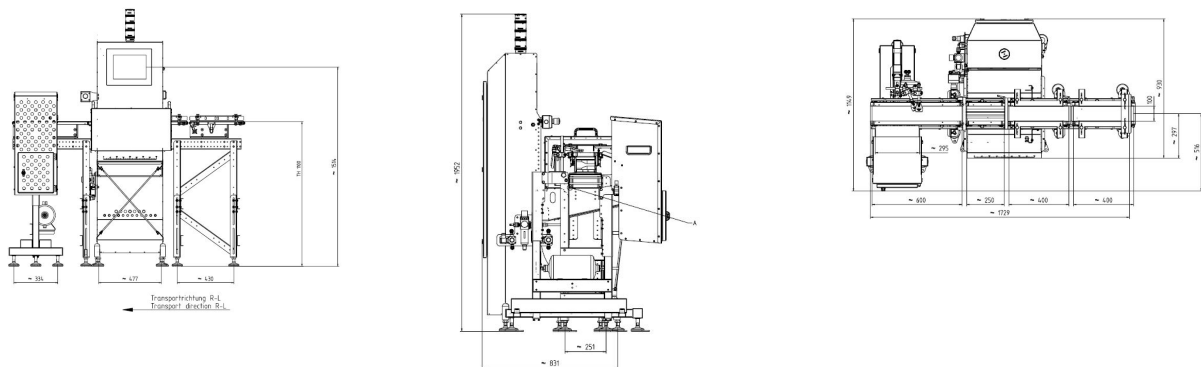

Bizerba SE & Co. KG
Wilhelm-Kraut-Straße 65
72336 Balingen

T +49 7433 12-0
fax: +49 7433 12-2696
marketing@bizerba.com

www.bizerba.com